



JANUARY 2005

Parts and Accessories

XWILSON **TRA**

Your Single Source For High Quality Parts & Accessories

Welcome to Wilson Xtra, the most convenient way to get high quality parts and accessories. Xtra is your one-stop shop for productivity-driven equipment for all types of punch press and press brake machines. Count on Xtra to deliver:

- ▼ A full line of tool and machine accessories for efficient, high quality fabrication
- ▼ Storage cabinets, punch and die grinders and hand tools to keep you running trouble free
- ▼ Replacement clamp assemblies and turret keys for most makes of turret punch presses
- ▼ Same day shipping to deliver your parts fast
- ▼ A commitment to meeting your needs with an ever-growing line of products
- ▼ The same great service you've come to expect from Wilson Tool

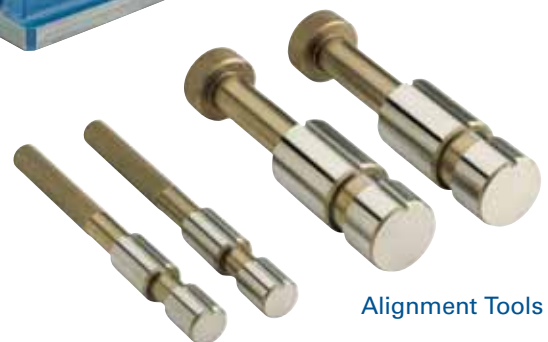

TABLE OF CONTENTS

| | |
|--|-------|
| Punch Press Tooling Accessories | 1-5 |
| ▼ Thick Turret Punch & Die Shims | 1 |
| ▼ Thin Turret & Strippit Style Punch & Die Shims | 2 |
| ▼ Slug Ejectors | 3 |
| ▼ Zip-Mar™ Adhesive Disks | 3 |
| ▼ Demagnetizer | 3 |
| ▼ T-Handle Extractor | 3 |
| ▼ Shear Grinding Fixture | 4 |
| ▼ Multi-Tool® Punch and Die Holders | 4 |
| ▼ Punch and Die Grinder | 5 |
| Punch Press Machine Accessories | 6-9 |
| ▼ Alignment Tools | 6 |
| ▼ Adapters | 7 |
| ▼ Ball Riding Die & Brush Die for Thick Turret Machines | 8 |
| ▼ Turret Bushings for Strippit Style Thin Turret Machines | 9 |
| Press Brake Tooling Accessories | 10-11 |
| ▼ Express Clamp Torque Wrench Kit | 10 |
| ▼ Urethane Rolls | 10 |
| ▼ Side Gauge & Protractor Accessories | 11 |
| ▼ Side Gauge | 11 |
| ▼ Back Gauge Stopper Plates/Pads | 11 |
| Tool Handling & Storage | 12-13 |
| ▼ Thick Turret & Thin Turret Tooling Cabinet | 12 |
| ▼ Press Brake Tooling Cabinet | 13 |
| Tool Assembly & Alignment | 14-16 |
| ▼ Adapters | 14 |
| ▼ Die and Stripper Adapters, Die Shims | 14 |
| ▼ Alignment Fixture | 15 |
| ▼ Assembly Fixtures, Vice Jaws | 16 |
| Hand Tools | 17-18 |
| Lubricants | 19 |

PUNCH PRESS TOOLING ACCESSORIES

THICK TURRET PUNCH & DIE SHIMS



| DIE SHIMS | | | |
|----------------------|------|----------|-------|
| .010 Thick (0.25 mm) | | | |
| Individually | | | |
| Station | Qty. | Cat. No. | Price |
| 1/2" (A) | 1 | 2101 | |
| 1-1/4" (B) | 1 | 2097 | |
| 2" (C) | 1 | 2089 | |
| 3-1/2" (D) | 1 | 2081 | |
| 4-1/2" (E) | 1 | 2073 | |
| Package | | | |
| Station | Qty. | Cat. No. | Price |
| 1/2" (A) | 25 | 2208 | |
| 1-1/4" (B) | 25 | 2209 | |
| 2" (C) | 10 | 2210 | |
| 3-1/2" (D) | 5 | 2211 | |
| 4-1/2" (E) | 5 | 2212 | |

| DIE SHIMS | | | |
|----------------------|------|----------|-------|
| .030 Thick (0.75 mm) | | | |
| Individually | | | |
| Station | Qty. | Cat. No. | Price |
| 1/2" (A) | 1 | 2721 | |
| 1-1/4" (B) | 1 | 2723 | |
| 2" (C) | 1 | 2725 | |
| 3-1/2" (D) | 1 | 2727 | |
| 4-1/2" (E) | 1 | 2729 | |
| Package | | | |
| Station | Qty. | Cat. No. | Price |
| 1/2" (A) | 25 | 2722 | |
| 1-1/4" (B) | 25 | 2724 | |
| 2" (C) | 10 | 2726 | |
| 3-1/2" (D) | 5 | 2728 | |
| 4-1/2" (E) | 5 | 2730 | |

| DIE SHIMS | | | |
|---------------------|------|----------|-------|
| .060 Thick (1.5 mm) | | | |
| Individually | | | |
| Station | Qty. | Cat. No. | Price |
| 1/2" (A) | 1 | 2104 | |
| 1-1/4" (B) | 1 | 2100 | |
| 2" (C) | 1 | 2092 | |
| 3-1/2" (D) | 1 | 2084 | |
| 4-1/2" (E) | 1 | 2076 | |
| Package | | | |
| Station | Qty. | Cat. No. | Price |
| 1/2" (A) | 25 | 2172 | |
| 1-1/4" (B) | 25 | 2173 | |
| 2" (C) | 10 | 2174 | |
| 3-1/2" (D) | 5 | 2175 | |
| 4-1/2" (E) | 5 | 2176 | |

| PUNCH SHIMS | | | | | | | |
|---------------------|------|----------|-------|-------------------|------|----------|-------|
| .060 Thick (1.5 mm) | | | | | | | |
| Individually | | | | Package | | | |
| Station | Qty. | Cat. No. | Price | Station | Qty. | Cat. No. | Price |
| 1/2" (A) | 1 | 1898 | | 1/2" (A) | 25 | 2167 | |
| 1-1/4" (B) | 1 | 1899 | | 1-1/4" (B) | 25 | 2168 | |
| 1-1/4" (B) Metric | 1 | 1898 | | 1-1/4" (B) Metric | 25 | 0098 | |
| 2" (C) | 1 | 1898 | | 2" (C) | 10 | 2169 | |
| 3-1/2" (D) | 1 | 1898 | | 3-1/2" (D) | 5 | 2170 | |
| 4-1/2" (E) | 1 | 1898 | | 4-1/2" (E) | 5 | 2171 | |

THIN TURRET & STRIPPIT STYLE PUNCH & DIE SHIMS

| PUNCH SHIMS | | | |
|--------------------|------|----------|-------|
| .060 Thick (1.5mm) | | | |
| Individually | | | |
| Station | Qty. | Cat. No. | Price |
| 1/2" | 1 | 0100 | |
| 1-1/4" | 1 | 0152 | |
| Package | | | |
| Station | Qty. | Cat. No. | Price |
| 1/2" | 25 | 0099 | |
| 1-1/4" | 25 | 0098 | |

| DIE SHIMS | | | |
|--------------------|------|----------|-------|
| .010 Thick (.25mm) | | | |
| Individually | | | |
| Station | Qty. | Cat. No. | Price |
| 1-1/4" | 1 | 2097 | |
| 3-1/2" | 1 | 2081 | |
| Package | | | |
| Station | Qty. | Cat. No. | Price |
| 1-1/4" | 25 | 2209 | |
| 3-1/2" | 5 | 2211 | |

| DIE SHIMS | | | |
|--------------------|------|----------|-------|
| .030 Thick (.76mm) | | | |
| Individually | | | |
| Station | Qty. | Cat. No. | Price |
| 1-1/4" | 1 | 2723 | |
| 3-1/2" | 1 | 2727 | |
| Package | | | |
| Station | Qty. | Cat. No. | Price |
| 1-1/4" | 25 | 2724 | |
| 3-1/2" | 5 | 2728 | |

| DIE SHIMS | | | |
|--------------------|------|----------|-------|
| .060 Thick (1.5mm) | | | |
| Individually | | | |
| Station | Qty. | Cat. No. | Price |
| 1-1/4" | 1 | 2100 | |
| 3-1/2" | 1 | 2084 | |
| Package | | | |
| Station | Qty. | Cat. No. | Price |
| 1-1/4" | 25 | 2173 | |
| 3-1/2" | 5 | 2175 | |

| DIE SHIMS FOR MULTI-TOOLS® | | | | | | | |
|----------------------------|----------------|-------|-----------------|--------------|-------|--------------------|-------|
| Machine Type | Station | Shape | Thickness | Individually | | Package of 15 each | |
| | | | | Cat. No. | Price | Cat. No. | Price |
| NISSHINBO | 3-1/2 – 8 | | .010" (0.25 mm) | 6800 | | 6815 | |
| NISSHINBO | 3-1/2 – 8 | | .030" (0.76 mm) | 6801 | | 6816 | |
| FINN-POWER® | MT 12 & 20 – 8 | | .010" (0.25 mm) | 6802 | | 6817 | |
| FINN-POWER® | MT 12 & 20 – 8 | Round | .030" (0.76 mm) | 6803 | | 6818 | |
| FINN-POWER® | MT 12 & 20 – 8 | Round | .010" (0.25 mm) | 6804 | | 6819 | |
| FINN-POWER® | MT 12 & 20 – 8 | Shape | .030" (0.76 mm) | 6805 | | 6820 | |
| FINN-POWER® | MT 6 & 10 – 16 | Shape | .010" (0.25 mm) | 6806 | | 6821 | |
| FINN-POWER® | MT 6 & 10 – 16 | | .030" (0.76 mm) | 6807 | | 6822 | |
| FINN-POWER® | MT 6 & 8 – 24 | | .010" (0.25 mm) | 6808 | | 6823 | |
| FINN-POWER® | MT 6 & 8 – 24 | | .030" (0.76 mm) | 6809 | | 6824 | |
| THICK TURRET | 1-1/4 – 5 | | .010" (0.25 mm) | 6810 | | 6825 | |
| THICK TURRET | 1-1/4 – 5 | | .030" (0.76 mm) | 6811 | | 6826 | |

PUNCH PRESS TOOLING ACCESSORIES

SLUG EJECTORS

Square Urethane

| Hole Dia. in Punch | Qty. | Cat. No. | Price |
|--------------------|------|----------|-------|
| 1/8" (3.2mm) | 50 | 6116 | |
| 3/16" (4.8mm) | 50 | 6117 | |
| 3/8" (9.5mm) | 50 | 6118 | |
| 1/2" (12.7mm) | 50 | 6119 | |
| Assortment | 50 | 6410 | |

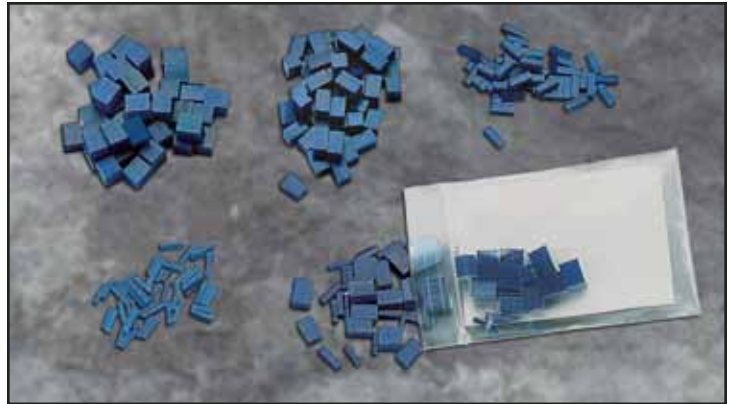

"ZIP-MAR" ADHESIVE DISKS™

| Station | Qty. | Cat. No. | Price |
|-----------------|-----------|----------|-------|
| 1/2" (A) | pkg. (10) | 6083 | |
| 1-1/4" (B) | pkg. (10) | 6084 | |
| 2" (C) | pkg. (10) | 6085 | |
| 3-1/2" (D) | pkg. (10) | 6086 | |
| (15.2 x 30.5cm) | pkg. (10) | 6087 | |
| Sheet | 1 | 6108 | |

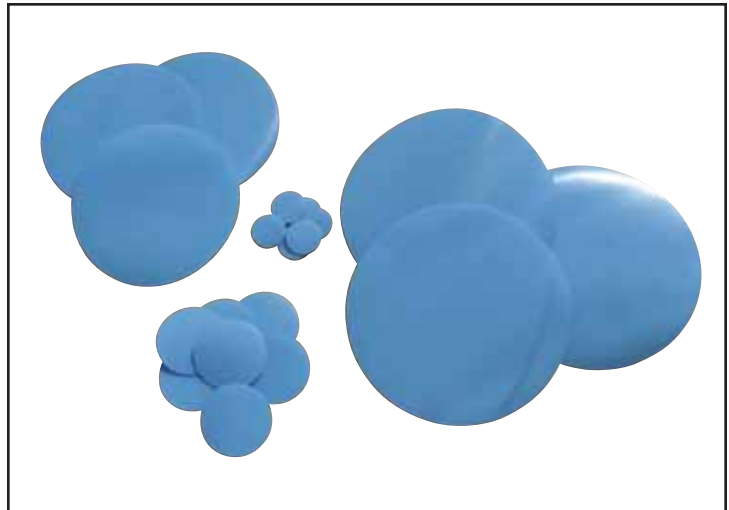

Zip Mar™ reduces the costly marring of material by the stripper. The disk is applied to the bottom of a standard stripping guide or stripper plate. A hole is then cut with a sharp knife to reveal the existing hole in the stripper.

T-Handle Extractor for large station guide assemblies.

Cat. No. 6483 PRICE



Demagnetizer

When a punch and die have been re-ground they will retain a certain amount of magnetism after being held by a magnetic chuck. Subsequent operations may necessitate the efficient demagnetizing of these parts. The Wilson Tool demagnetizer will prove invaluable for this purpose. Cat. No. 24304. Call for Pricing.



SHEAR GRINDING FIXTURE



SHEAR GRINDING FIXTURE & ACCESSORIES FOR THICK TURRET MACHINES

| Description | Cat. No. | Price |
|-------------------------------------|----------|-------|
| Shear Grinding Fixture | 6034 | |
| 1/2" Tooling Sleeve Adapter | 6043 | |
| 1-1/4" Tooling Punch and Die Holder | 6042 | |
| 1-1/4" to 1/2" Die Adapter | 6088 | |
| Series 80°/90° Tooling Punch Holder | 6040 | |
| Pointer (Replacement) | 6035 | |
| Degree Scale (Replacement) | 6036 | |

MULTI-TOOL® PUNCH & DIE HOLDERS FOR THICK TURRET MACHINES

| Description | Cat. No. | Price |
|---|----------|-------|
| 8 Station Thick/Thin Punch & Die Holder | 6812 | |
| 8mm Punch & Die Holder | 6156 | |
| 16mm Punch & Die Holder | 6157 | |
| 24mm Punch & Die Holder | 6158 | |

SHEAR GRINDING FIXTURE & ACCESSORIES FOR THIN & STRIPPIT STYLE THIN TURRET MACHINES

| Description | Cat. No. | Price |
|---|----------|-------|
| Shear Grinding Fixture | 6034 | |
| 1/2" Tooling Sleeve Adapter | 6045 | |
| 5/8" Tooling Sleeve Adapter | 6046 | |
| 1-1/4" Tooling Punch and Die Holder | 6044 | |
| 2 & 3-1/2" Full Body Punch Holder | 6039 | |
| 3-1/2" Punch Holder – Strippit Style | 6041 | |
| Universal Notch Punch Holder – Strippit Style | 6071 | |
| Pointer (Replacement) | 6035 | |
| Degree Scale (Replacement) | 6036 | |

MULTI-TOOL® PUNCH & DIE HOLDERS

| Description | Cat. No. | Price |
|---|----------|-------|
| 8-Station Strippit Style Multi-Tool® Punch & Die Holder | 6159 | |
| 8mm Finn-Power® Punch & Die Holder | 6156 | |
| 16mm Finn-Power® Punch & Die Holder | 6157 | |
| 24mm Finn-Power® Punch & Die Holder | 6158 | |

Local
Tel: 651-286-6001
Fax: 651-286-5959

Toll Free U.S.A. & Canada
Tel: 800-328-9646
Fax: 800-222-0002

Toll Free Mexico
Tel: 001-800-741-2510
Fax: 001-800-544-2096

Website & Email
www.wilsontool.com
salesdesk@wilsontool.com



WILSON PUNCH & DIE GRINDER

The Wilson Punch & Die Grinder is the latest in a long line of Wilson Tool products designed to help you work smarter—not harder.

Designed by DCM specifically for resurfacing punches and dies, it can save you time, space and money compared to existing sharpening methods. Here's how:

- 5 hp spindle motor. Handles large dies easily.
- CBN grinding wheel. Provides aggressive material removal rates and a high-quality surface finish.
- Dual coolant application. Coolant is supplied both externally and through the spindle for maximum heat removal while grinding—helping to maintain tool integrity.
- Regrind punches up to 10° angle. The punch fixturing allows sharpening of rooftop and straight angle shear punches with angles up to 10° and everything in between.
- Simple fixturing design. Allows for quick, easy loading and unloading of parts and accurate, repeatable process control.
- Auxiliary magnetic chuck standard. Accommodates items that cannot be secured in the three-jaw chuck.
- Autofeed. Frees up the operator to perform other shop duties during the grinding process and allows for accurate cut depths.
- Heavy-duty three-jaw chuck standard. Will accommodate all punches and dies up to 6" (152 mm) diameter.
- Small footprint. At 40" x 48" (101 x 122 cm), the Wilson Punch and Die Grinder requires minimal floor space.

In addition, the grinder comes standard with a rigid, heavy-duty 18" (45.7 cm) diameter rotary table that eliminates any chance for the chatter common with smaller tables.

To learn more about the new Wilson Punch & Die Grinder and how to invest in this effective, economical means to maximize punch and die life, please contact your local Wilson Tool representative, or call our sales desk at 800-328-9646.



2" (C) TO 1-1/4" (B) STATION ADAPTER

| Description | Cat. No. | Price |
|---|----------|-------|
| 230V 3 Phase 30 Amp PDG grinder | 6854 | |
| 460V 3 Phase 20 Amp PDG grinder | 6855 | |
| 1/2 gallon coolant mix | 6856 | |
| 5 gallon coolant mix | 6857 | |
| Coolant filter pack (50 sheets) | 6858 | |
| 6" replacement CBN wheel | 6859 | |
| Production coolant filtration system | 6860 | |
| Replacement filter roll for filtration system | 6861 | |

ALIGNMENT TOOLS



| ALIGNMENT TOOLS FOR SINGLE TRACK MACHINES | | | | |
|---|------------|-------|------------|-------|
| | Upper Unit | | Lower Unit | |
| Station | Cat. No. | Price | Cat. No. | Price |
| 1/2" (A) | 2597 | | 2598 | |
| 1-1/4" (B) | 2599 | | 495 | |



| ALIGNMENT TOOLS FOR MULTIPLE TRACK MACHINES | | |
|---|----------|-------|
| Station | Cat. No. | Price |
| 1/2" (A) | 2601 * | |
| 1-1/4" (B) | 2602 * | |

*Note: Two of each Cat. No. required.



| ALIGNMENT TOOLS | | | | |
|-----------------|------------|-------|------------|-------|
| | Upper Unit | | Lower Unit | |
| Station | Cat. No. | Price | Cat. No. | Price |
| 2" (C) | 1840 | | 1841 | |
| 3-1/2" (D) | 1947 | | 1948 | |
| 4-1/2" (E) | 1949 | | 1950 | |
| 6" (F) | 2290 | | 2291 | |



| ALIGNMENT TOOLS FOR THIN TURRET MACHINES | | | | |
|--|------------|-------|------------|-------|
| | Upper Unit | | Lower Unit | |
| Station | Cat. No. | Price | Cat. No. | Price |
| 1-1/4" | 0494 | | 0495 | |
| 3-1/2" Strippit Style | 0496 | | 0497 | |
| 2" | 3350 | | 1841 | |
| 3-1/2" | 3251 | | 1948 | |

Note: Not for use in Auto Index Station.

ADAPTERS

THICK TURRET 2" (C) TO 1-1/4" (B) STATION ADAPTER

| Description | Cat. No. | Price |
|--|----------|-------|
| Punch & Guide Assembly Adapter (Keyed at 0° & 180°) | 2284 | |
| Die Adapter | 2475 | |



THICK TURRET 2" (C) TO 1-1/4" (B) STATION ADAPTER

| Description | Cat. No. | Price |
|--------------------------------|----------|-------|
| Punch & Guide Assembly Adapter | 2476 | |
| Die Adapter | 2475 | |



THICK TURRET 3-1/2" (D) TO 1-1/4" (B) STATION ADAPTER

| Description | Cat. No. | Price |
|--|----------|-------|
| Punch & Guide Assembly Adapter (not shown) | 2492 | |
| Die Adapter | 35058 | |

Note: Maximum material thickness for above adapters: .135" (3.4 mm) mild steel and aluminum, .090" (2.3 mm) stainless steel.

STRIPPIT STYLE THIN TURRET ADAPTER TO ACCEPT 1-1/4" STATION TOOLING

| Description | Cat. No. | Price |
|------------------------------|----------|-------|
| 3-1/2" Station Punch Adapter | 10059 | |
| 3-1/2" Station Die Adapter* | 10096 | |

* Keyed 4 ways for use in all machines



BALL RIDING DIE & BRUSH DIE FOR THICK TURRET MACHINES

The "Ball Riding Die," which consists of a spring loaded ball, has been designed to help eliminate several problems. The most common problems result from the higher height of the form-up dies.

These problems are:

- Sheet hang-up from the material running into a higher die, such as a forming tool.
- Sheet deformation from punching next to dies of different heights.
- Damage to forming die inserts when the die cap receives uneven loading during punching in neighboring stations.

To reduce sheet and tool damage in forming applications, two of these dies are placed in stations surrounding the forming tool. When the sheet approaches the form-up die, it is lifted by the ball riding die. When the forming operation begins, the ball in the surrounding die recesses with the sheet. Once the form has been achieved and the tool strips, the spring loaded balls lift the sheet back to its original height. This allows the sheet to move more freely through the turret, avoiding collisions with the form-up tool.

Placing these dies into the vacant stations on a turret loaded on one side can also eliminate material crashes.



| BALL RIDING DIE | | |
|-----------------|----------|-------|
| Station | Cat. No. | Price |
| 1/2" (A) | 2375 | |
| 1-1/4" (B) | 0482 | |
| 2" (C) | NA | |
| 3-1/2" (D) | NA | |
| 4-1/2" (E) | NA | |
| 6" (F) | NA | |

The primary use for brush dies is in applications where any marking that might be caused by ball riding dies is not acceptable.



| BRUSH DIE | | |
|------------|----------|-------|
| Station | Cat. No. | Price |
| 1/2" (A) | 2760 | |
| 1-1/4" (B) | 2761 | |
| 2" (C) | 2762 | |
| 3-1/2" (D) | 2763 | |
| 4-1/2" (E) | 2764 | |

TURRET BUSHINGS FOR STRIPPIT STYLE THIN TURRET MACHINES



TURRET BUSHINGS

| Station | Machine Model(s) | Keying | Cat. No. | Price |
|---|---|---------------------------|----------|---------------------------------------|
| 1-1/4" (2.437"/ 61.9 mm flange O. D.) | For use in any SAF that utilizes Strippit® 1-1/4" Tool Holder Assembly #62532-000 or #62515-000, as well as the following: T-SAF-30, FC75/30, FC750, FC1000 (I & II), FC1250 and Cap 1000 | 0° - 90° (Standard) | 0015 | |
| | | 0° - 90° - 180° & 270° | 0490 | |
| | | 0° - 45° - 270° & 315° | 0491 | |
| | | 0° -135° - 225° & 270° | 0492 | |
| 1-1/4" (2.375"/ 60.3 mm flange O. D.) | FC1000 III & 33 STN. 1250, FC1000R | Available as listed above | 0471 | (0° - 90° Std.) (Multiple Keyways) |
| 3-1/2" | FM-30-30 | 1-Keyway | 0280 | |
| 3-1/2" | For use in any SAF that utilizes Strippit® 3-1/2" Tool Holder Assembly #62530-000 or #93023-100, 200, as well as the following: T-SAF-30, FC75/30, FC750, FC1000 (I, II & III), FC1250 and Cap 1000, all XT & "S" Series machines. | 1-Keyway | 0277 | |

EXPRESS CLAMP TORQUE WRENCH KIT, URETHANE ROLLS



| EXPRESS CLAMP TORQUE WRENCH KIT | | | |
|---------------------------------|----------|-------|-----------|
| Description | Cat. No. | Price | Kit Price |
| Complete Kit | 8002 | | |
| Case | 8003 | | 1/Kit = |
| Pivots | 43726 | | 2/Kits = |
| Wrench | 6793 | | 1/Kit = |
| Hex Tips | 6795 | | 2/Kits = |



| URETHANE ROLLS FOR MARK-FREE BENDING | | |
|--------------------------------------|----------|-------|
| Dimensions | Cat. No. | Price |
| .015 [0.4] x 6" [152] | 42530 | |
| .030 [0.8] x 6" [152] | 42531 | |

*Note: Urethane dies are also available. Contact application sales desk for pricing and lead times.

Local
Tel: 651-286-6001
Fax: 651-286-5959

Toll Free U.S.A. & Canada
Tel: 800-328-9646
Fax: 800-222-0002

Toll Free Mexico
Tel: 001-800-741-2510
Fax: 001-800-544-2096

Website & Email
www.wilsontool.com
salesdesk@wilsontool.com



SIDE & BACK GUIDE ACCESSORIES

SIDE GAUGE & PROTRACTOR ACCESSORIES

| Dimensions | Cat. No. | Price |
|---------------------------------------|----------|-------|
| 1. Side Gauge and Protractor Assembly | 42702 | |
| 2. 1V Die Stabilizer | 42704 | |
| 3. 2V Die Stabilizer | 42705 | |

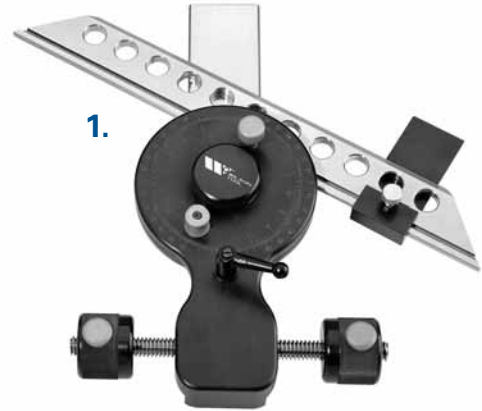

(Includes Cat. No. 42704 & 42705)

SIDE GAGE

| Description | Cat. No. | Price |
|-------------|----------|-------|
| Side Gage | 42701 | |



*Note: Intended for use with Quick Change, 2V, Sectionalized 2V, and Quick Change 1V Dies.

QUICK CHANGE BACK GAUGE STOPPER PLATES/PADS

| Dimensions | Cat. No. | Price |
|--|----------|-------|
| 1. Adjustable Back Gauge Stopper Plate | 42703 | |
| 2. Replacement Pad | 42707 | |
| 3. Sheet Support Pad | 42708 | |
| 4. Single Point Pad | 42709 | |
| 5. Reworkable Pad | 42712 | |

*Note: Quick Change Back Gauge Stopper Pads are for Amada Style Back Gauges.



WILSON THICK TURRET & THIN TURRET TOOLING CABINET



Cabinet includes lock with two keys and forklift base. Dimensions: 42" (107 cm) high x 28" (71 cm) wide x 29" (74 cm) deep.

Standard color: Classic Blue (Thick Turret), Guardian Green (Fabricating)

Note: Tool cabinets are shipped motor freight-collect



| THICK TURRET TOOLING CABINET | | |
|------------------------------|----------|-------|
| Description | Cat. No. | Price |
| Thick Turret Tooling Cabinet | 90001 | |
| Options | | |
| Plastic Drawer Liners | 90002 | |
| Mobile Base | 90003 | |
| Maple Top | 90004 | |
| Cart Handle (1) | 90005 | |
| Ribbed Rubber Mat | 90006 | |

Features

8 Drawer Arrangement & Capacity Consisting of:

3 Drawers for 1/2" (A) Station Tooling:

- 18 Punch & Guide Assemblies (per drawer)
- 36 Dies & 18 Additional Punches (per drawer)

3 Drawers for 1-1/4" (B) Station Tooling:

- 12 Punch & Guide Assemblies (per drawer)
- 24 Dies & 12 Additional Punches (per drawer)

1 Drawer for 2" (C) Station and 3-1/2" (D) Station Tooling:

- 12 2" or 3-1/2" Station Punches, Stripper Plates and Dies

1 Drawer (9 compartments) for 4-1/2" (E) Station Tooling:

- 6" (F) Station Tooling, Large Station Guide Assemblies and Misc.

| THIN TURRET TOOLING CABINET | | |
|-----------------------------|----------|-------|
| Description | Cat. No. | Price |
| Fabricating Tooling Cabinet | 90000 | |
| Options | | |
| Plastic Drawer Liners | 90002 | |
| Mobile Base | 90003 | |
| Maple Top | 90004 | |
| Cart Handle (1) | 90005 | |
| Ribbed Rubber Mat | 90006 | |

Features

9 Drawer Arrangement & Capacity consisting of:

6 Drawers for 1-1/4" Station Tooling:

- 18 Punch & Guide Assemblies (per drawer)
- 36 Dies & 18 Replacement Punches (per drawer)

2 Drawers for 3-1/2" Station Tooling:

- 16 Sets of 3-1/2" Station Tooling (per drawer)

1 Drawer (9 Compartments) for Guide Assemblies:

- 5" Station Tooling or Miscellaneous Fabricating Tooling.

Local
Tel: 651-286-6001
Fax: 651-286-5959

Toll Free U.S.A. & Canada
Tel: 800-328-9646
Fax: 800-222-0002

Toll Free Mexico
Tel: 001-800-741-2510
Fax: 001-800-544-2096

Website & Email
www.wilsontool.com
salesdesk@wilsontool.com



PRESS BRAKE TOOLING CABINET**TOOLING CABINET**

| Description | Cat. No. | Price |
|-----------------------------|----------|-------|
| Press Brake Tooling Cabinet | 9007 | |

Features

- Solid steel construction
- Mobile base with heavy duty casters with a rated capacity of 900 pounds each
- Three 7" drawers capable of holding five punches each
- Two 2" drawers capable of holding five dies each
- Punches are held upright in custom steel U-channels to prevent damage to tips and mounting tongues
- Dies are separated by custom U-channels to prevent damage to V-openings
- Individual latches on all drawers
- Safety interlock to prevent the opening of more than one drawer at a time
- Full width handles with end caps and paper labeling strips with clear protective label covers
- Retainer top with rubber mat
- Cabinet dimensions: 42" high, 40-1/4" wide, 22-1/2" deep



ADAPTERS

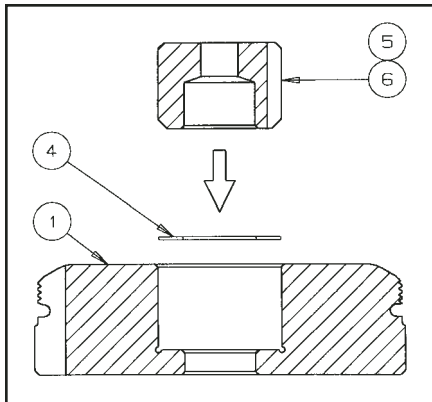

| SIZE 0 DIE ADAPTER COMPONENT PARTS | | | | |
|---|------------------|-------|--------------------|-------|
| Description | Group S Machines | | All Other Machines | |
| | Cat. No. | Price | Cat. No. | Price |
| 1. Full Die Adapter assembly, including shim pack but not including Size 0 die. | 25380 | | 25381 | |
| 2. 6.5mm DIA steel ball. (Not Shown) | 25387 | | 25387 | |
| 3. M8 x 10 long Socket Set Screw. (Not Shown) | 25391 | | 25391 | |
| 4. Shim Pack (2 x .004" [0.10mm], 1 x .012" [0.30mm], 1 x .020" [0.5mm]) | 25388 | | 25388 | |
| 5. Size 0 Die (Round) | 25149 | | 25149 | |
| 6. Size 0 Die (Shape) | 25150 | | 25150 | |

Features

The Wilson Tool designed adapters are a low cost die option for size 0 tooling. When used in conjunction with a punch chuck, only new punch and die inserts need to be purchased for each new size and shape.

Design criteria

- Size 0 dies are manufactured from M2 High Speed Steel as standard.
- Die adapters are manufactured from high quality tool steel for long life.
- Die adapters are high precision for accurate tool loading.
- Size 0 dies are compatible with 6-station Multi-Tool.

Information needed

- Size, shape and angular position required for die orders.
- Material type and thickness required for die orders.
- Machine model.

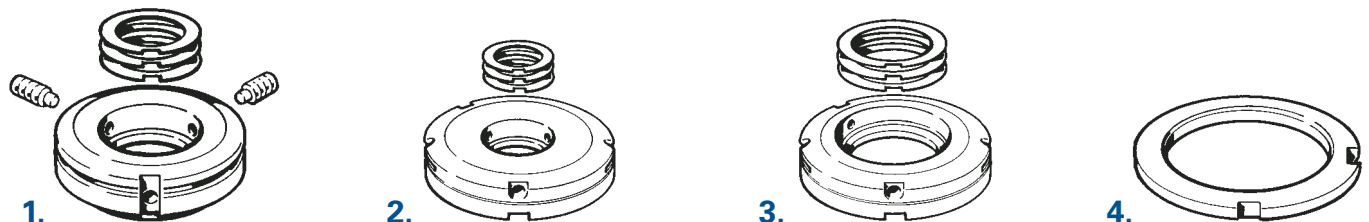

| DIE AND STRIPPER ADAPTERS, DIE SHIMS | | | |
|--------------------------------------|--------------------------------------|----------|-------|
| Size | Description | Cat. No. | Price |
| I to II | 1. Die Adapter, machine groups F/H | 25165 | |
| I to III | 2. Die Adapter, machine group G | 25168 | |
| II to III | 3. Die Adapter, machine group G | 25167 | |
| II to III | 4. Stripper Adapter, machine group G | 25155 | |
| I | Shim Pack for size I Dies* | 25181 | |
| II | Shim Pack for size II Dies* | 25182 | |

*Includes 1 each of .5 and .3 shims and 2 each of .1 mm thick shims

ALIGNMENT FIXTURE

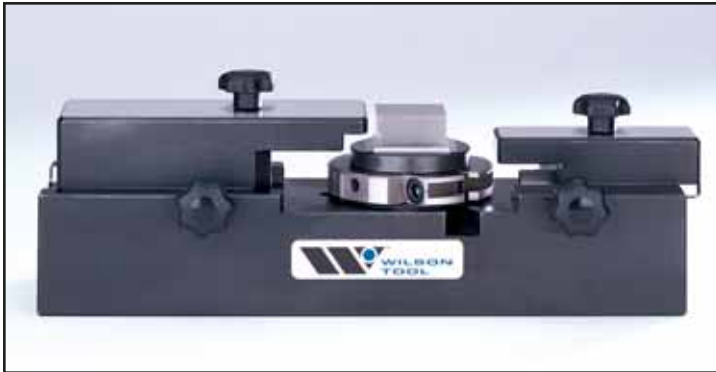

ALIGNMENT FIXTURE

| Description | Cat. No. | Price |
|-------------------|----------|-------|
| Alignment Fixture | 24186 | |

Features and Benefits

- Simplified, economical design.
- Robust yet portable fixture.
- Precision-made body with very few wearable parts.
- Angle settings of 0°-45°-90°.
- Easy to use—regrind length chart included.
- Extremely accurate.
- Ergonomically designed.
- **Versatile.** The fixture can take all types of Trumf-style collars: Size I, Size II, Minimatic-style, Heavy Duty, Manual, plus forming tools that do not have integral collars. Can be used for flat and whisper-style punches.
- **Variety.** Suitable for Trumf, Pullmax, Omes, Euromac, Kunz and Boschert machines.

ASSEMBLY FIXTURES, VICE JAWS



Thick Turret Assembly Fixture, C & D Stations

Bench mounted aid for assembling and retaining C & D Station Thick Turret guide assemblies.

Cat. No. 24162 Call for Pricing.



Thick/Thin Turret Strippit Nylon Vice Jaws

Tailored vice jaws to aid in the assembly and maintenance of A & B Station Thick Turret and 1-1/4" Station Thin/Strippit style punch assemblies

Cat. No. 24001 Call for Pricing.



Strippit Style 3-1/2" Assembly Fixture

Bench mounted aid for assembling and maintaining 3-1/2" Strippit style guide assemblies.

Cat. No. 24161 Call for Pricing.



Trumpf Style Assembly Fixture

Bench mounted aid for assembling and maintaining 2-4-1 punch assemblies and Trumpf style tooling.

Cat. No. 24182 Call for Pricing.



Spring Disassembly Tool

For use with large station guide assemblies.

Cat. No. 8104 PRICE



Pullmax Style Assembly Fixture

Bench mounted aid for assembling and maintaining Pullmax style tool holders and punch assemblies.

Cat. No. 24813 Call for Pricing.

HAND TOOLS

Sure Shot Sprayer
1-QT (.95 liter) capacity.
Cat. No. 6120 PRICE



SAE Hex Key Wrench Set
Cat. No. 6057 PRICE



Metric Hex Key Wrench Set
Cat. No. 6105 PRICE



Soft Face Hammer
Cat. No. 6106 PRICE



Tru-Arc Pliers
Cat. No. 6056 PRICE

HAND TOOLS



Rubberized Abrasive Wheel
For removing galling.
Cat. No. 8050 PRICE



Spanner Wrench
Cat. No. 6058 PRICE



Oil Stone
Cat. No. 6060 PRICE



Diamond File
Cat. No. 6059 PRICE



| TOOL KIT | | |
|--|----------|-------|
| Description | Cat. No. | Price |
| Tool Kit; contains the following: | 6091 | |
| (1) Tool Box, (1) Oil Stone, (1) Diamond File, (1) Tru-Arc Pliers, (1) Spanner Wrench, (1) Punch Lubricant, (1) Soft Face Hammer, (1) Metric Hex Key Wrench Set, (1) Hex Key Wrench Set (English), (1) Assortment of 4-sizes of square urethane ejectors. | | |

LUBRICANTS**Punch Lubricant**

Cat. No. 6055 PRICE

Visit us at www.wilsontool.com

“Our goal is to deliver the most reliable, innovative, durable, and consistent tools, such that our customers can be the most successful fabricators in the world.”

Toll Free Order Desk

U.S. & CANADA
tel 1-800-328-9646
fax 1-800-222-0002

MEXICO
tel 001-800-741-2510
fax 001-800-544-2096

BELGIUM
tel 0032-14257474
fax 0032-14257475

DENMARK
tel 80 20 20 24
fax 80 20 20 26

IRISH REPUBLIC
tel 1-800-709009
fax 1-800-535538

NORWAY
tel 800 10809
fax 800 10803

SWEDEN
tel 020 79 14 19
fax 020 79 14 18

FINLAND
tel 09-3512569
fax 09-3513769

or
tel 06-4764300
fax 06-4764301

FRANCE,
SWITZERLAND
tel 0800-90-8488
fax 0800-90-8520

GERMANY, AUSTRIA,
SWITZERLAND,
THE NETHERLANDS
tel 00800-9457668665
fax 00800-945766329



Xtra Tooling Division
12912 Farnham Avenue
White Bear Lake, MN 55110

Tel (Free): 800-328-9646
Fax (Free): 800-222-0002
Email: salesdesk@wilsontool.com

WILSON TOOL INTERNATIONAL

Wilson Tool International, Inc. United States

12912 Farnham Avenue
White Bear Lake, MN 55110 USA
Tel (Free): 800-328-9646
Tel: 651-286-6001
Fax (Free): 800-222-0002
Fax: 651-286-5959
Email: marketing@wilsontool.com

Wilson Tool International, Ltd. United Kingdom

Stirling Road, South Marston
Industrial Estate, Swindon,
Wiltshire, SN3 4TQ England
Tel (Free): 0800-373748
Tel: +44 1793 831818
Fax (Free): 0800-373758
Fax: +44 1793 831945 or 46
Email: sales@wilsontool.co.uk

Wilson Tool International China LLC

Rm 2F/C No.1076 Jiangning Road
Shanghai 200060 China
Tel: +86 21 62660958
+86 21 62662396
Fax: +86 21 62662364
Email: ldtool@guomai.sh.cn

Wilson Tool International Germany

Gottlieb Daimler Str 2
31552 Rodenberg, Germany
Tel (Free): 00800-9457668665
Tel: +49 5723 747 0
Fax (Free): 00800-945766329
Fax: +49 5723 747 10
Email: verkauf@wilsontool.eu.com

Wilson Tool International A/S Denmark

Islevdalvej 100
DK-2610
Roedovre, Denmark
Tel (Free): +80 20 20 24
Tel: +45 44 53 1699
Fax (Free): +80 20 20 26
Fax: +45 44 53 0607
Email: sales@wilsontool.dk